

Centrisys Corporation

Centrifuges vs Belt Filters

THE COMPARISON AND SELECTION OF SEPARATIONS EQUIPMENT FOR THE MUNICIPAL INDUSTRY (Centrifuges versus Belt Filters)

Prepared By:
Centrisys Corporation
Robert G. Havrin



TABLE OF CONTENTS

II.	Historical	3 - 5
III.	Current Market Conditions	5 - 6
IV.	Belt Filter Press Design	6 - 9
V.	Centrifuge Design	9 - 10
VI.	Industry requirements	10 - 11
VII.	Comparative Process Performance	11 - 19
VIII.	Comparative Operating Costs	20 - 21
IX.	Bibliography	22

INTRODUCTION

The municipal market is a mature industry. As such, equipment used in various applications has been around for a while but continues to evolve slowly in response to market demands. This paper will briefly review earlier separations equipment, list some of the major technical developments of the last 20 years and then provide an up-to-date summary of what end users need to consider before selecting equipment for their systems, personnel and processes.

HISTORICAL

Rotary Vacuum Filters. Soon after municipal plants began to proliferate, there was a need to further concentrate solid wastes beyond what was possible by gravity thickening. To meet this need, *rotating vacuum filters* became an integral component in the design of wastewater treatment facilities and remained the preferred dewatering device until the middle part of the 20th century.

Centrifugally Enhanced Separation. Due to increasing environmental awareness, the municipal industry began to grow and so did the competition for separations equipment. By 1950, centrifugal separators began to make an impact on the market place. Over the next 20 years, there was a marketing shake-out over which style(s) of centrifuge would best serve the municipal market. Both *batch (vertical basket)* and continuous equipment (decanters and disk) were put to the test. In the end, batch equipment did not make the cut. The feed delivery systems and batch cycles were too complicated, capacity per unit of floor space too limited and operation less reliable than other commercial offerings.

High-speed disk centrifuges, commonly used in the food and pharmaceutical industries, seemed an ideal choice for thickening waste activated sludge. The equipment had high capacities (in a reduced floor plan) and was simple to operate. However, maintenance was an unexpected nightmare. Typical sludge found at a municipal plant is a non-homogeneous mixture of solids which includes biomass, fine sand/silt and the infinite other types of solids that can be supplied from domestic

sources. And, whatever makes it through the bar screens and a grit chamber can ultimately go through the centrifuge. In the end, the disk centrifuge failed because the design was not robust. Amorphous plastics plugged the restrictive nozzle openings. As an after thought, remediation was attempted with fine screening and cyclones; however, a fine less than 325

mesh sand fraction resulted in excessive wear to the sintered tungsten carbide inserts and costly repairs to the periphery of the high speed bowl.

Filtration. In response to the same market demands and in competition with centrifugal separators, other filtration equipment began to take over the dominant position once held by rotary vacuum filters. *Plate-and-Frame Presses* became the first separations device to challenge rotary vacuum filters for market share. And their descendent, the *Membrane Filter Press*, is still used today in both wastewater and water treatment plants. However, similar end user demands (reference batch centrifugal equipment) then and now continue to limit the market share for this type of equipment.

The Belt Filter Press had an evolutionary path derived from pulp dewaterers found in the Pulp and Paper Industry (and hence the similarity to paper machines). First designed in the early 1960's, the potential in the municipal market was envisioned and successfully applied by Alb. Klein, K. G. to an anaerobically digested sludge in West Germany (mid 1960's). Shortly afterward, Ralph B. Carter Co. (Klein Licensee) and Smith and Loveless began the successful introduction of Belt Filter Presses in the United States.

Evolving Competition. By the end of the 1960's, the reign of the vacuum filter was over due to the emergence superior competition – first decanter centrifuges and shortly after by belt filter presses. The abrupt exodus of this technology was further accelerated by the development of advanced water treatment polymers synergistically compatible with centrifuge and belt press operation. Both of these designs could more effectively apply compressive forces to further concentrate cake solids.

The 1970 - 1980's provided the backdrop in the battle for market share between emerging technologies. The different technologies would

compete against each other as well as amongst themselves. The energy crisis (which was a legacy of this era) shifted the market share, as typically delineated by plant size, in favor of belt filter presses. In short, belt presses offered competitive if not superior performance to most of the centrifuge manufacturers. Economic evaluations needed to rationalize installed costs with power and polymer consumption for similar levels of cake dryness. Typically, belt filter presses had lower installed and electrical costs while centrifuges operated with 20 – 30 % less polymer consumption.

The battle for market share catalyzed the rapid development of technology in centrifuges resulting in improved performance and greater capacities for the same footprint. Over the 20 year span, the design of the municipal decanter changed dramatically to meet the demands of market conditions as follows:

- *Maintenance reliability* via the application of advanced hardfacing technology – i.e. from Colmony 6 and Stellite (2000 – 3000 hours) to sintered tungsten carbide tiles (+15,000 hours).
-
- *Improved cake solids* via the integration of manually adjustable backdrive controls and rudimentary auto-torque regulation systems.
- *Reduced polymer consumption* via proprietary design features.

The technology of belt filter presses also improved during this time frame, but not to the extent of centrifuges. Improvements in cloth design included increased strength and better cake release properties and hence less fouling via weave patterns and special calendaring of the cloth. Proprietary features for pre-thickening and pre-concentrating the cake solids prior to higher pressure dewatering were developed to reduce the hydraulic limitations. However, the main focus, due to the large number of competitors (over 20 suppliers and 5 major players), became cost reduction with emphasis on the frame, bearings, and supports.

CURRENT MARKET CONDITIONS

Concerning new equipment types, continuous screw press dewatering equipment has begun to test the dewatering market with about a dozen installations nationwide. At present, this offering is an interesting experiment. The design offers some of the same advantages as decanter centrifuges – ie a closed system, dryer cake solids than a belt filter press, etc as well as power consumption similar to a belt filter. But, the design is less flexible than conventional offerings and has already demonstrated a wider deterioration in performance attributes whenever the biomass fluctuates or the content is increased beyond a certain threshold. As such, the personnel in any installation using this technology need to be more attentive and take the appropriate precautions.

The main competition, however, remains the same. Over the last twenty years, the change in design for belt filters and centrifuges has been less dramatic.

Instead, major changes have occurred in the way business is conducted. Both centrifuge and filter manufacturers rely a lot more on outsourcing the manufacture of equipment and have cut back on sales forces in favor of manufacturing representatives. Similarly, all manufacturers are taking advantage of the revolution in computing to 1) shorten delivery times, 2) facilitate the packaging of integrated dewatering systems and 3) promote greater integrated process control.

Rapidly changing business plans have also had a toll on companies in the marketplace. In the 1980's, Sharples and Humboldt collectively boasted well over a 90 % share of the centrifuge municipal market in the North America. This dominance was earned via the application and control of new technology. What they could not control, however, was the downsizing and takeover mania of the 1990's. A new era had dawned. With the expiration of patents and after downsizing core competencies within these groups, no new enabling technologies emerged. Instead, a cross-pollination of talent resulted in more similar process designs than ever before.

Major players in the municipal market for centrifuges (\$ 50 – 100 million per year) now include:

Alfa Laval
Andritz
Centrisys, currently the only US made centrifuge for the municipal market
US Filter
Westfalia

Concerning belt filter presses, industry leaders (\$ 60 – 70 million) were more stable and would include Arus Andritz, Ashbrooke-Simon Hartley and Komline Sanderson. However, there has been a significant turnover in the fortunes of regional manufacturers and vendors.

BELT PRESS DESIGN

Process Configuration - Belt Filter Zones. Based on function, belt filters can be used for thickening, dewatering and high solids dewatering. To better understand the difference in designs, a belt filter can be divided into the following zones:

- Feed / Chemical Conditioning. Common to all belt filters, sludge conditioning using polymer and/or other chemicals is arguably the most important

parameter in achieving competitive performance and operating costs. Two types of mixers have been used – rotating drums and in-line mixers. Further, rotating drums can be either a standalone mixer or a mixer thickener. Typically, the amount of shear and contact time are part of the system control parameters. Currently, in-line mixing with alternate polymer injection points is the preferred method of in-line mixing.

- Gravity Thickening Section. Common to all belt filters, free water from sludge conditioning is removed in the gravity thickening section of the belt filter and thickened to 5 – 15% (depending on the sludge type). The design of this section will vary depending on whether a two-belt,

three-belt, rotary drum thickener or plow blades are used. Two- and three- belt systems typically use an incline of 5 – 15 degrees.

- Plow blades are used when feed solids are thin or when the gravity thickening section needs to be shortened. At the discharge of this section, manufacturing subtleties are added to enhance uniform solids loading across the width of the belt.
- Wedge Zone. The purpose of the wedge zone is to create a uniform semi-cake prior to dewatering. The orientation of the wedge zones can be horizontal, vertical or with positive and negatives slopes.
- Pressure/Shear Compression Zone. Final cake dryness is determined by the amount of time cake solids spend in the shear compression zone. Further, shear is increased as the cake solids increase by using progressively smaller rollers. Time and shear therefore determine the difference between Conventional and High Solids Belt Filter Press dewatering. Conventional designs use 8 pressure rollers while High Solids Models use 14 – 15 pressure rollers. A nip roll, an extra high pressure section, is not typically used as the added pressure achieved dryness improvement but often at the expense of capacity, recovery and belt life.
- Cake Discharge Section. The final section of the belt filter is the cake discharge section. The design objective is to promote as clean discharge from the cloth so that wash and solids recycle is minimized. This is accomplished by gravity, roller orientation or scrapper blades. Scrapers are a design concern and can adversely influence belt life.

In summary, the proper operation of a belt filter and optimum process performance can be summarized as a 5 step series of dependent events. The limitation of the belt filter is the weakest link in the series relative to a particular application.

Mechanical Operation. The process features of the design are also a function of the mechanical reliability of the set-up referenced to long-term operating conditions. Therefore, the end user needs to be able to decide whether an economy model or a Cadillac is right for the equipment life-cycle.

The features which need to be compared are summarized as follows:

- Belts. The technology associated with belt design is the limiting factor in belt filter performance. Belts are selected based on the best combination of attributes for the following:
 - Tensile, Yield and Impact Strength, Plastic Creep – the ability to handle tension without excessive stretching or deformation.
 - Permeability and pore size – the ability to retain solids but allow liquid to pass through under conditions of tension and pressure.
 - Cake release properties
 - Resist to fouling as caused by polymer, grease and solids accumulating in the pore spaces.

The most common belts used today are woven nylon and polyester monofilament fiber. Further these belts can have a calendared surface for promoting cake release.

Belts used typically handle tensions of 10 – 20 pounds per inch of belt width and range in weight from 2.5 – 5 oz/ft². The belt life in a filtration applications can be mechanically limited (torn or worn) or process limited (when fouling or plugging interferes with performance). Belts used in high pressure sections have an estimated life of 2,000 – 3,000 hours (guarantee usually given by an OEM).

A clipper seam is typically used to connect the belts. Seamless belts are also possible and may have an extended life; however, they are more troublesome to install.

- Belt tension. The amount of belt tension needed is a function of the sludge type and needs to be built into the frame, rollers, bearings and tensioning system. Typical designs are for 10 – 50 pounds / inch of belt length. Increasing tension generally increases the cake dryness up to the point solids extrude out of the sides of the belts. The downside of increasing tension is reducing belt life. Pneumatics or hydraulics can be used to adjust the belt tension. Hydraulic pressure is preferred by most operators and permits the use of smaller peripheral components. However, this option is also more expensive. Pneumatic cylinders are simpler, require less power (70 psi can be generated by as little as 1 HP) and provide for a cleaner operation. The disadvantage is the need for instrument air.

- Belt alignment and tracking. The preferred method of belt alignment and tracking is via a skewing roller that continuously adjusts lateral tension loadings versus direct side pressure which leads to premature belt wear.

The purpose of such tracking is to promote continuous uniform pressure across the entire belt width. Along with frame stiffness and roller deflection, this is essential for promoting uniform cake solids across the belt. Therefore, a simple test for rigidity is to sample the cake solids axially across the belt and look for trends.

- Belt washing system. There is a considerable spread in the recommendations given by OEMs regarding belt washing. Washing rates from 25 – 30 GPM/M at 80 psi to up to 110 GPM/M of belt width and 130 psi have been recommended. Thus design and long-term application determines what is actually needed. Therefore booster pumps are needed to supply the amount and pressure of water needed. Typically, the belt washing system uses wash water along with recycled effluent. Therefore, scum and sludge traps should be design into the system to validate what is being recycled.
- Bearing life. Special bearings are designed on a roller-by-roller basis for premium offerings. As so designed, bearing life up to 40,000 hours have been quoted. Standard sealed bearings are not effective in this service with life expectancies of 2,000 – 4,000 hours.
- Frames and Supports. Belt filter frames are made of tubular steel, C or U channel and I-beams using stainless and carbon steel. Proper welding is the superior form of construction, but bolting is also common and used if warping is an issue. Cantilevered designs are more operator friendly – especially when changing seamless belts. However, a more rigid frame is required and is therefore more expensive.

In summary, long-term reliable process performance and mechanical design are inter-related. Sampling of cake solids across the axial length of the belt is a method of validating the long-term reliability of both.

DECANTER CENTRIFUGE DESIGN

Decanter Centrifuge System Design. Numerous changes have occurred over the last 20 years which have re-energized the emergence of centrifuges into the municipal market place. These changes are summarized as follows:

- More competitively derived market pricing.
- Greater System Integration. Twenty years ago, centrifuge manufacturers only supplied centrifuges. Now, most centrifuge manufacturers commonly supply dewatering systems that integrate feed sludge pumps, polymer conditioning systems and cake conveyance operation/safety functions

through a central controller that is compatible with centrifuge operating parameters. Further, product delivery times have been dramatically reduced by as much as 30 – 60 %. Currently, integrated dewatering systems can be supplied in as little as 6 – 24 weeks depending on the size and complexity of the configuration.

- Continued Design Evolution. Centrifuge designs have continued to evolve and are now approaching design optimization limits. Increasing the G-level beyond 3000 has only achieved modest levels of process improvement and potentially at the expense of additional capital cost and mechanical reliability (maintenance is a geometric function of the speed). The main advances in decanter centrifuge design over the last 20 years are summarized as follows:
 - L/D ratio increased from 3 to 4+. The result is higher capacities/diameter and lower power consumption/GPM relative to earlier larger designs.
 - More sophisticated back drive controllers. Centrifuge back drive controllers are now set-up to accurately sense the cake solids level inside the centrifuge as a function of the conveyance torque and friction factor of dewatered solids inside the centrifuge.

- Proprietary feed chamber designs. In contrast to earlier feed chamber designs whose accelerators wore out prematurely and offset process performance, current designs improve process performance while reducing wear both in the feed zone and at the tips of the conveyor.

INDUSTRY REQUIREMENTS

Capital cost. Many of the industry requirements have already been outlined in this paper. Pricing for equipment in the municipal industry, due to the many suppliers, needs to be very competitive. As with other industrial offerings, the initial capital cost needs to be compared to the price of operating/maintaining equipment and plant personnel need to work within the limitations of how such monies are distributed. Hence, different types of economic evaluations are used to validate a particular selection.

Service and technical support. Just as important, however, O & M personnel need to be comfortable with their involved role in the equipment being purchased. Therefore, plant management needs to be pro-active in the selection process. Does the plant have the necessary tools and do plant personnel have the necessary training to properly operate the equipment? If not, how much will this cost? What type of maintenance needs to be performed in-house and what

type of maintenance should be sub-contracted out? While the up front costs are reasonably well known, the total maintenance costs need to be carefully researched.

Such homework should be done well in advance of any equipment purchase. And, when gathering such information, the recommendation is strongly made to talk to people in similar plants who work with equipment from a particular supplier. One of the biggest tragedies of the last 20 years is service on equipment after the sale. In fact, an article was written in *Business Week* several years ago entitled *Why Service Sucks*. All manufactures occasionally run into problems – as this is a fact of life. And, most problems involve a two-party solution. What is most important then becomes how pro-active was the company in solving a particular problem? Responses can vary from “.... cut us a purchase order and we will look into it” to “... we will send someone over right away”.

Therefore, choose the company you would prefer to work with on a long-term basis.

Historical preference. Historically, plant personnel have preferred equipment that is easy to operate and maintain as seen by the domination of continuous versus batch type of equipment. More recently, continuous screw presses have entered the market. Whether this is a new trend or whether marketing/design issues compromise growth is unclear at this time.

Health issues. Finally, health and safety issues are becoming more important each year. As such, there is an increasing tendency for industry to trend to closed systems whereby operators are removed from process fluids, vapors and aerosols. This trend favors self-contained centrifuge systems.

COMPARATIVE DESIGN PERFORMANCE

Comparative design performance will focus on mechanical reliability coupled to the process capability of the separations equipment. Mechanical reliability includes the ease of operation (consistency of results, ease of optimization, ability to integrate with peripheral equipment, etc.), maintenance (routine and scheduled servicing, downtime, etc) and the ability to promote a safe and hygienic environment. Process capabilities would include the design capabilities of a separation process application – ie recovery, polymer dosage, cake dryness, etc.

Common variations to biomass processed at waste water treatment plants can include the following:

- Annual (+/- 50 %) or daily changes in the feed concentration (+/- 10 %).
- Seasonal considerations as to the feed composition
- Random loadings of industrial waste
- Multiple sludge types



Mechanical comparison. Given that significant variations in sludge consistency can exist at most treatment plants, how reliable are the different dewatering systems? And, based on typical plant operating practices, how does the start-up, optimization and shutdown compare?

Start-up. A centrifuge and accompanying support equipment is typically ready to run in 15 – 30 minutes after pressing the start button. The systems are fully automated and can be pre-programmed with various design curves that can anticipate the expected sludge type. Similarly, a belt press can come on line. However, changing belt types to accommodate a particular sludge type is not a practical option.

Optimization. A modern centrifuge is far simpler to optimize than a belt filter. This is due to having less than half the major variables versus a belt filter and more reliable feedback information. With settings approximated from earlier pre-set conditions, centrifuge optimization typically involves minor adjustments of the polymer level and Viscotherm backdrive control. The following schematic summarizes the general optimization logic on a Centrisys centrifuge system:

SCHEMATIC OF CENTRISYS DEWATERING SYSTEM

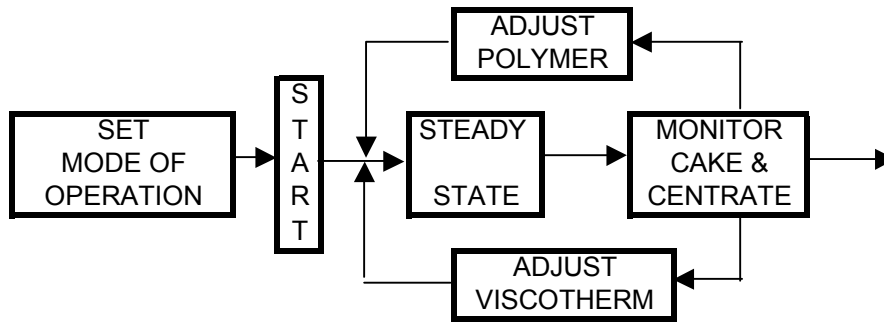

In a Centrisys Dewatering System, the more the equipment is run, the more finely tuned the set-up becomes. Not only does the centrifuge controller automatically start the centrifuge system, the control package also allows the operator to pre-select what mode the centrifuge should operate in. As such, the centrifuge is typically 95 % optimized within 45 minutes of start-up. The Viscotherm backdrive controller gives instant feedback (via a pressure correlation) of the cake solids level more accurately than can

be determined by visual observation. Further, once the desired pressure is achieved, the Viscotherm backdrive system maintains this cake solids level in spite of changing feed concentration via an integral proportional controller. Thus by occasionally observing the centrate and adjusting the polymer accordingly, the system stays optimized.

The same is not true of a belt filter press. First, the condition of the belt is assumed. What this means is that adjustments, over time, change as the belt stretches and/or loses permeability. Therefore, any pre-settings of the belt tension and speed are less reliable. Next, sludge conditioning needs to be compatible with the various process sections of the design. Once up and running, visual observation is the only means of reliable instant feedback. Therefore, observations of the cake consistency not only depend on the axial distribution across the belt but also on the human element making the visual determination. Estimations of the recovery level are more vague. Fines are lost through the cloth but also extruded out the sides. This fact combined with high cloth wash rates make estimates of recovery, even from conscientious operators, fairly unreliable.

Under these scenarios, what should be expected if the sludge characteristics begin to change? First, there would be a greater need for direct operator intervention on a belt filter press. Second, with a high degree of uncertainty in process feedback, only more noticeable departures from normal operation are effectively attended to resulting in most belt filter presses operating below their optimum levels of efficiency in spite of significantly more manual interaction.

In conclusion, higher levels of performance need continuous operator attention to insure all sections of the belt filter work synergistically together. Even then, less than optimum performance should be expected.

BELT FILTER PRESS OPTIMIZATION

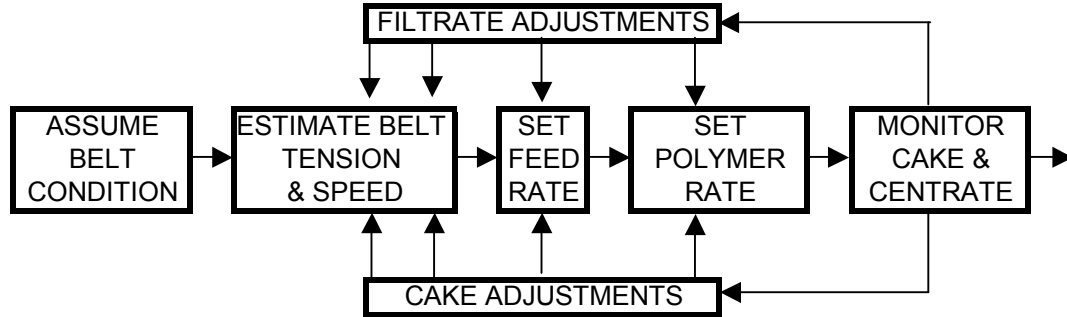

Shut Down. The shutdown of a Centrisys dewatering system is fully automated and in a closed system. After initiating shutdown on a touch screen controller, no further human interaction is required. All components will shutdown and clean themselves in the process.

A comparative summary of the benefits of each is as follows:

SUMMARY - A MECHANICAL COMPARISON OF DEWATERING SYSTEMS	
<p>CENTRISYS DECANTER</p> <p>Advantages</p> <ul style="list-style-type: none"> Reduced installation costs Reduced labor costs Maintenance Operator No janatorial costs Cleaner work area Reduced odor and aerosol problems Reduced unplanned downtime Reduced spare parts costs/inventory Simpler operation Much simpler start-up and shutdown 	<p>BELT FILTER SYSTEM</p> <p>Advantages</p> <ul style="list-style-type: none"> Lower equipment capital cost Lower energy consumption

Process Performance. Municipal sludge and performance expectations are difficult to fully classify due to wide ranging variations of different processes as well as domestic and industrial contributions to the biomass. There is a need to 1) define sludge characteristics, 2) characterize optimum performance levels

expected on the equipment and 3) give case histories on actual performance levels typically achieved by equipment operating in plants.

Sludge definitions. To better quantify performance, limits need to be set and terms better qualified. Therefore, all sludge types as defined, assume industrial contributions are less than 20 % of the final dewatered solids concentration and that conventional wastewater treatment processes are employed. Further, chemical additives (such as potassium permanganate used in odor control) are assumed not to significantly affect sludge conditioning. Concerning polymer dosages, dewatering centrifuges typically operate at 0.7 – 1.3X the belt press dosage depending on the mode and cake dryness level desired. For thickening applications, centrifuges typically operate at 0.25 – 0.35 X the belt filter dosage. The following assumptions are made in the performance estimates listed in Table 1:

- Raw Primary. The feed solids are assumed to come off the bottom of a primary clarifier and therefore have a consistency of 2 – 7 % w/w ts. For thickening prior to anaerobic digestion or tanker hauling, cake at 5 – 10 % w/w ts is specified at +95 % recovery and is easily obtainable.
- Waste Activated Sludge. Most feed solids vary from 0.4 – 2.0 % w/w tss. Sludge thickening without polymer yields a 4 – 6 % cake for recovery specs of 85 – 90%. Polymer is required at higher level of recoveries and/or while thickening at 7 – 10%. Dewatering and high solids dewatering typically occurs at 90 – 95 % recovery levels.
- Raw Mixed Primary /Secondary Sludge. Various combinations of mixed primary and secondary sludge are usually found at a concentration between 3 – 6 % w/w tss. This analysis assumes a 50:50 blend of sludge types. Recovery levels of + 95 % are typically achieved using polymer for all modes of separation.
- Mixed Anaerobically Digested Sludge. Assuming a 50:50 blend of primary and secondary sludge to the digester, feed solids at 2 – 4 % w/w tss typically result in specifications at + 95 % recovery with polymer.
- Aerobically Digested Sludge. For aerobically digested sludge, feed solids at 1 – 2.5 % w/w tss typically result. Polymer is used to effect separations at 90 – 95 % w/w recovery.

Optimized Performance Capabilities. Table 1 is a summary of the comparative process performance level typically achieved for fully optimized dewatering systems. In the top

chart, typical scale-up capacities of belt filter presses and Centrisys centrifuges are listed. For both centrifuges and belt filter presses, the same capacities are listed for regular and high solids dewatering. In reality, high solids dewatering would slightly reduce the capacities for both designs. However, such charts should be kept as simple as possible as there can be significant departures outside the common range of performance listed in the tables. The bottom charts list the dewatering characteristics of conventional and high solids designs.

In summary, centrifuges have more process flexibility and higher levels of performance than can be expected from belt filter presses.

Finally, the capacity table for thickening equipment is not complete at this time. As expected, cake dryness is a function of residence time. With this limitation removed from both types of equipment, capacity can dramatically increase. The belt filter and centrifuge design changes eliminate the compression sections of the machines to better facilitate increased throughput. Rough estimates are for 2X capacity when going from dewatering to thickening.

TABLE 1. COMPARATIVE PROCESS PERFORMANCE LEVEL

MUNICIPAL WASTEWATER SLUDGE PROCESSING					
Common Sludge Type Scale-Up - Dewatering and High Solids Dewatering					
	Primary	P:S/1:1	WAS	Digested	
				Anaerobic	Aerobic
EQUIPMENT	Capacities, pph ss				
BFP/M	1,800 - 2,500	900 - 1700	400 - 1000	900 - 1500	400 - 900
CS 10-4	400 - 900	350 - 700	70 - 200	300 - 600	100 - 300
CS 14-4	1,000 - 2,000	800 - 1,500	160 - 500	700 - 1,300	300 - 700
CS 18-4	2,000 - 4,000	1,700 - 3,500	340 - 1,200	1,300 - 2,400	600 - 1,500
CS 21-4	4,100 - 7,900	3,400 - 6,900	700 - 2,500	2,500 - 5,000	1,000 - 3,500
CS 21-4 HC	5,000 - 9,000	4,000 - 8,000	800 - 3,000	3,000 - 6,000	1,500 - 4,000
CS 26-4	7,000 - 18,000	6,400 - 12,500	1,300 - 5,000	5,000 - 10,000	2,800 - 6,500
CS 30-4	14,000 - 25,000	10,000 - 20,000	2,000 - 8,000	10,000 - 20,000	4,000 - 10,000

MUNICIPAL WASTEWATER SLUDGE PROCESSING					
Common Sludge Type Performance - Conventional Dewatering					
	Primary	P:S/1:1	WAS	Digested	
				Anaerobic	Aerobic
EQUIPMENT	Cake Dryness, % w/w ts				
BFP/M	23 - 30	18 - 25	12 - 20	18 - 25	12 - 20
Decanter	20 - 28	18 - 24	12 - 18	18 - 24	15 - 20

MUNICIPAL WASTEWATER SLUDGE PROCESSING					
Common Sludge Type Performance - High Solids Dewatering					
	Primary	P:S/1:1	WAS	Digested	
				Anaerobic	Aerobic
EQUIPMENT	Cake Dryness, % w/w ts				
BFP/M	25 - 33	20 - 28	12 - 20	20 - 28	14 - 23
Centrisys HS	32 - 40	28 - 34	16 - 25	25 - 37	18 - 26



Case Studies. While the above chart defines the case of optimized equipment performance levels, earlier discussions have suggested that actual belt filter performance typically does not achieve the results of commissioning or pilot testing due to inherent flaws in the design and competitive commercial practices. The following case studies illustrate those points.

Case 1 Summary. Testing in the summer of 2005 was on an Aerobically Digested, Whole Aerated Extended Aeration sludge (1.5 – 2.5 % feed solids). Pilot testing was a comparison between a Centrisys CS 18-4 dewatering system and versus a 2 year old, 1.5 M belt filter press. The belt filter press was operated at 50 GPM (500 pph ss) and generated a 15 % w/w ts cake. The centrifuge was operated at 75 – 105 GPM (750 – 1050 pph ss) while generating cake solids at 20 – 23 % w/w ts cake. These results are consistent with Table 1. The belt filter press is at the lower limit of the design estimates while the centrifuge is at the upper limits. *In summary, the Centrisys CS 18-4 centrifuge system would be expected to produce 6 % dryer cake discharge versus the belt filter press.* The following graph is from the field test report:

Figure 3. Backdrive control of cake solids

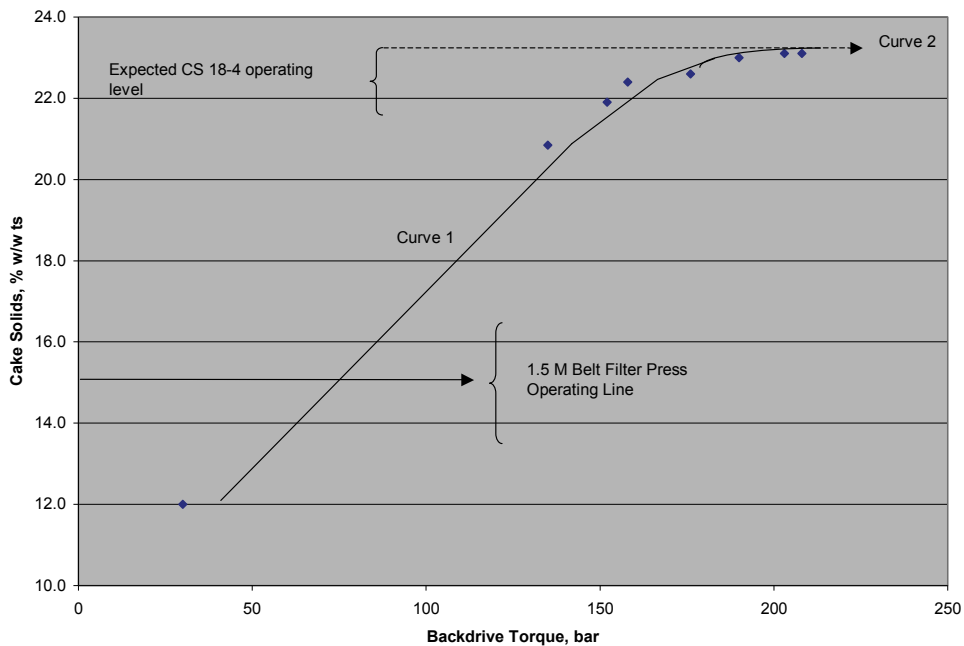

Case 2 Summary. Testing in the summer of 2005 was on a Mixed Anaerobically Digested Sludge (1 – 4, 3 average % feed solids). Pilot testing was a comparison between a Centrisys CS 18-4 dewatering system versus older, 2 M belt filter presses. The belt filter press was operated at 125 GPM (1877 pph ss) and generated 15 - 20 % w/w ts cake. The centrifuge was operated at 75 – 105 GPM (900 – 1500 pph ss) while generating cake solids at 28 – 33 % w/w ts cake. In comparison, the belt press was operating at the lower limits of the capacity

and cake dryness suggested by the estimates. The centrifuge was operated within the design range estimates of Table 1. *In summary,*

up to 13 % dryer cake should be expected if a centrifuge was installed in this facility. The following graph is from the field test report:

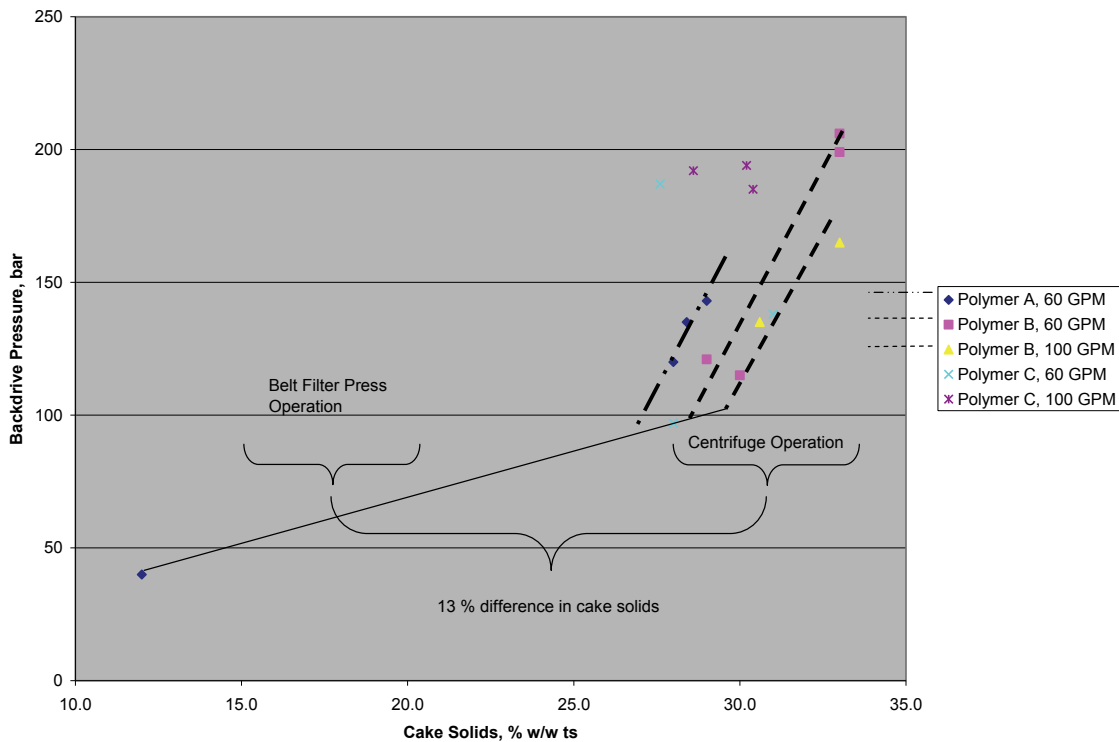

Case Study 3. Testing in the summer of 2005 was on a Thickened Waste Activated Sludge (3 – 4 % w/w ts). Pilot testing was a comparison between a Centrisys CS 18-4 dewatering system versus a 2.2 M belt filter press. The belt filter press was operated at 150 GPM (2627 pph ss) and generated a 13.5 % w/w ts cake. The centrifuge was operated at 50 – 70 GPM (875 - 1225 pph ss) while generating cake solids at 20 - 22 % w/w ts cake. In comparison, the belt press was operated at 200 pph above typical solids loading estimates of Table 1 due primarily to pre-thickening versus the 2% basis for the table performance estimation. As expected, cake solids on the belt filter press are at the lower levels of what should be expected. The centrifuge was operated within the

design range estimates of Table 1. *In summary, a 7 - 8 % improvement in dryness should be expected if a centrifuge was installed in this facility.* The following graph is from the field test report:

Figure 2. Viscotherm Controller

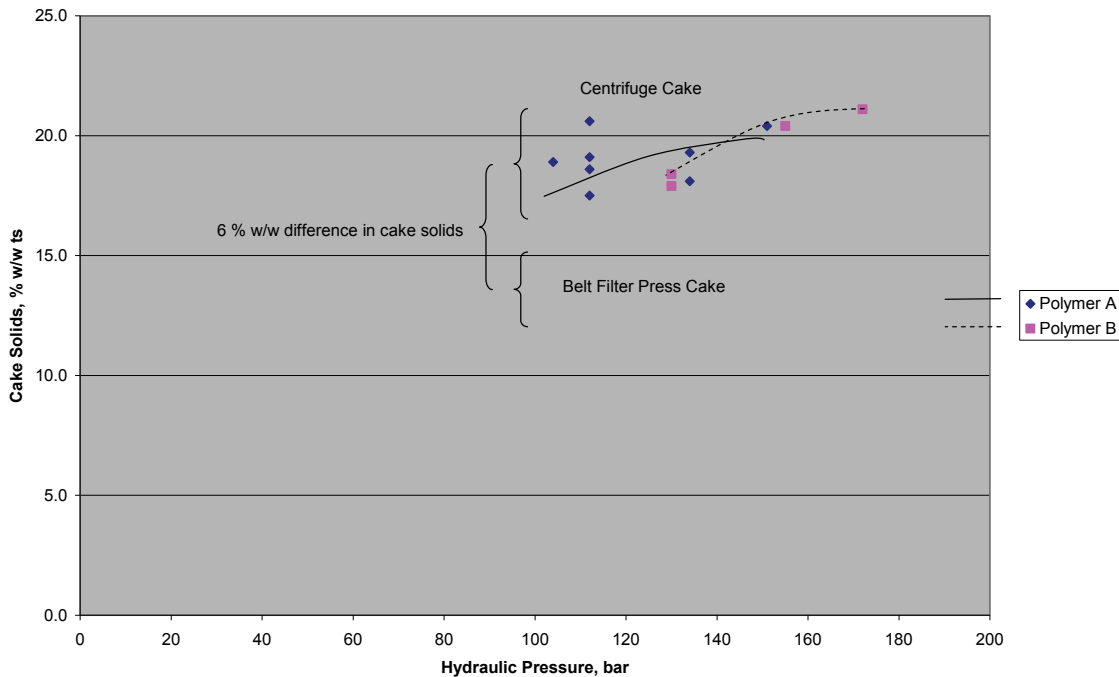

COMPARATIVE DEWATERING COSTS

Belt filter press designs are limited to less than 4 meters in width due primarily to geometrically increasing fabrication costs as the size increases beyond 2.5 meters. The same is also true relative for belting costs and their ease of installation. Instead then, after 2.5 Meters in length, multiple units are more typically sold. In this way, costs/GPM of sludge reach a design limit. For a 2 belt system, the range of equipment and equipment systems can vary as follows:

BELT FILTER PRESS SIZE, Meter	EQUIPMENT / SYSTEM COST, Dollars	BELT SET COSTS
0.5	50 - 150,000	
1.0	75 - 250,000	3,000 - 10,000
1.5	150 - 250,000	
2.0	175 - 350,000	6,000 - 25,000
2.5	200 - 375,000	

The design of all competitive decanter centrifuges now include automated backdrive controls along with advanced wear protection. The largest variations in cost would be seen in the inclusiveness of the peripherals and the complexity of the automated dewatering system. The following chart summarizes the capital cost for Centrisys equipment/systems:

CENTRISYS MODEL SIZE	EQUIPMENT / SYSTEM COST, Dollars
CS 10-4	100,000 - 200,000
CS 14-4	130,000 - 250,000
CS 18-4	200,000 - 350,000
CS 21-4	250,000 - 400,000
CS 21-4 HC	275,000 - 425,000
CS 26-4	400,000 - 600,000
CS 30-4	525,000 - 750,000



As mentioned earlier, centrifuges can offer a significant advantage in terms of saving on **installation costs**. Belt presses designs have a limitation as to how much dewatering can occur within a certain floor space as determine by the belt width. The same is not true with centrifuges. The capacity/floor space footprint increases geometrically with the diameter of the bowl. In addition, centrifuges can be operated at higher flow rates, if necessary, by sacrificing cake dryness or by increasing the polymer dosage. This attribute can allow for future savings in design retrofits where expanding the building is not practical. Also, reducing the number of installed units decreases the demand as required by peripheral support equipment in modular designs – ie the number of feed polymer and booster pumps; comminutors; flow monitoring equipment; etc.

Costs for such items as the polymer delivery system should be similar between units. Other costs such as the additional plumbing for wash requirements are unique to belt filter presses. Another potentially significant savings in installation costs would be in the cost for ventilation. Finally, a centrifuge can be installed outside in warm climates. This is not practical for belt filter presses which must be covered.

Based on total operating costs, the decanter centrifuge has significant advantages over the belt filter press. These are summarized as follows:

1. **Electrical costs** – the belt filter press has an advantage in electrical consumption. However, this difference is between 2 – 5 % of the total operating cost of the system.
2. **Conditioning costs** – a centrifuge can be operated at slightly higher polymer dosage for much dryer cake solids or at lower dosage levels for the same cake solids level versus a belt filter press depending on whether cartage or conditioning costs are controlling.
3. **Operator attention** – current estimates are that centrifuges require $\frac{1}{4}$ the labor of belt filter presses.
4. **Major servicing for centrifuges**
 - a. STC spray on conveyer tips with a useful life between 2,000 – 8,000 hours depending on the application.
 - b. STC tiles would have a useful life between 15,000 – 40,000 hours depending on the application.
5. **Major servicing of belt filter presses**

- a. 2,000 – 3,000 per belt depending on the application.

BIBLIOGRAPHY

1. Centrisys Municipal Applications Database
2. Centrisys Field Test Reports
3. Commercial Contacts
4. Unpublished Competitor Bid Packages
5. Circulated Articles
 - Sludge Management – Changing Times by S. Kellog
 - Decanter or Band Press Filter by Dipl. Ing. Henry Schabinger

 - Improving Belt Filter Press Performance by R. Lecey
 - The Belt Filter Press – Applications and Design by E. P. Austin
 - Comparison of Continuous Solid Bowl Centrifuges versus Belt Filter Presses by RGHavrin (1980)